

UQK-651 系列

自检式船用浮球液位控制器

MARINE FLOATING BALL LIQUID LEVEL CONTROLLER

使用说明书

INSTRUCTION MANUAL

辽阳双华仪表有限公司

LIAOYANG SHUANGHUA INSTRUMENT Co.,Ltd

## ● UQK-65 -C-Z 型船用浮球液位控制器

### MARINE FLOATLEVEL CONTOLLER

UQK-65-C系列船用浮球液位控制器适用于舰船敞开容器内液位控制。当液位处于高位或低位时，浮球开关动作，发出报警信号。

UQK-65-C-Z是在UQK-65-C的基础之上增加了自检功能，即自检式船用浮球液位控制器。它可以在设备运行状态下，搬动操作手柄，对控制器及系统进行检测，以确保控制器及系统安全运行。

UQK-65-C series top mounting type of marine float level controller is used for the level control in the opening or pressure container of ship. When the level is high or low the float switch works and alarms.

UQK-65-C-Z is added self-check function on the basis of UQK-65-C,namely Self-check Marine Float Level Controller.Which can be moved the operating handle to detect the controller and system under the state of equipment working in order to assure the controller and system operate safely.

### ● 技术参数 TECHNICAL SPECIFICATION

型 号 Model	UQK-651-C/Z
安装形式 Mounting type	侧装 Horizontal mounting
开关结构 Switch type	单点两位式 SPDT
触点容量 Contact capacity	SPDT AC: 220/10A DC: 125V/0.6A
切换差 Switching error	20~70 (mm)
介质比重 Medium gravity	≥0.85g/cm <sup>3</sup>
介质温度 Medium temp	≤150℃
工作压力 Working pressure	1.0MPa
防护等级 Protection	IP68
法兰标准 Flange standard	GB2506-89
浮球直径 Float dia. D mm	60

### ● 型号标记 MODEL SIGN

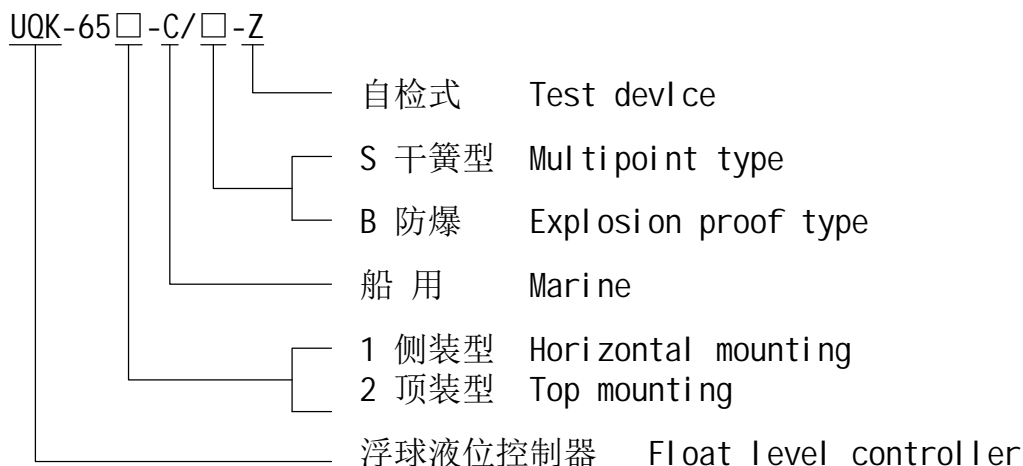

● 外型尺寸图 OUTLINE DIMENSLON

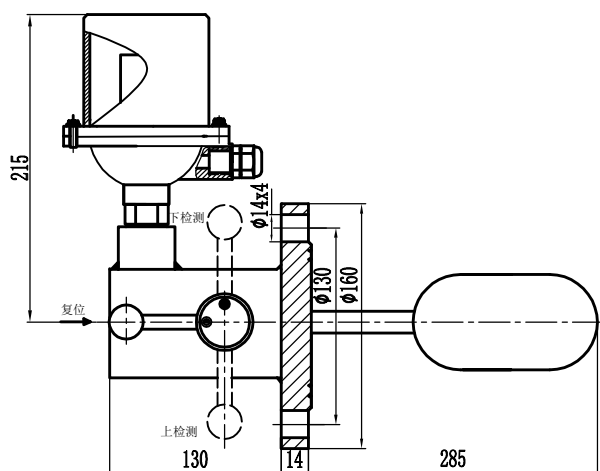

UQK-651-C-Z

注意事项：UQK-651-C-Z侧装自检式船用浮球液位控制器，在检测时将手柄向下旋转60~90°使检测机构动作，开关报警达到检测的目的，手柄组件在出厂时由复位锁紧螺丝锁紧，检测时将复位锁紧螺丝松开，检测后手柄复位，复位锁紧螺丝锁紧。

Matters needing attention The UQK-651-C-Z side installs the self-checking type ship with the float fluid position controller, when examination 60°C ~ 90°C causes handle downward revolving the examination organization movement, the switch to report to the police achieved examination goal, handle module when exwork by replacement lock screw locking, when examination will reposition the lock screw to locking, after the examination the handle will reposition, replacement lock screw locking.

● 接线图 WIRING DLAGRAM

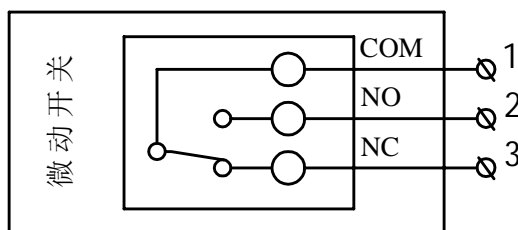

微动开关原理图

辽阳双华仪表有限公司

地址: 辽阳市太子河区荣兴路中段122号

电话: 0419-4154068 4153466

传真: 0419-4153422

邮编: 111000

网址: [www.lyshyb.com](http://www.lyshyb.com)

邮箱: [lyshyb@lyshyb.com](mailto:lyshyb@lyshyb.com)

LIAOYANG SHUANGHUA INSTRUMENT Co.Ltd

Address: No. 122 Middle Rongxing Road, Taizi River District, Liaoyang City

Tel: 0419-4154068 4153466

Fax: 0419-4153422

Zip: 111000

Http: [www.lyshyb.com](http://www.lyshyb.com)

Email: [lyshyb@lyshyb.com](mailto:lyshyb@lyshyb.com)